

 **SENNHEISER**

Wireless Listening Pleasure
RS 125

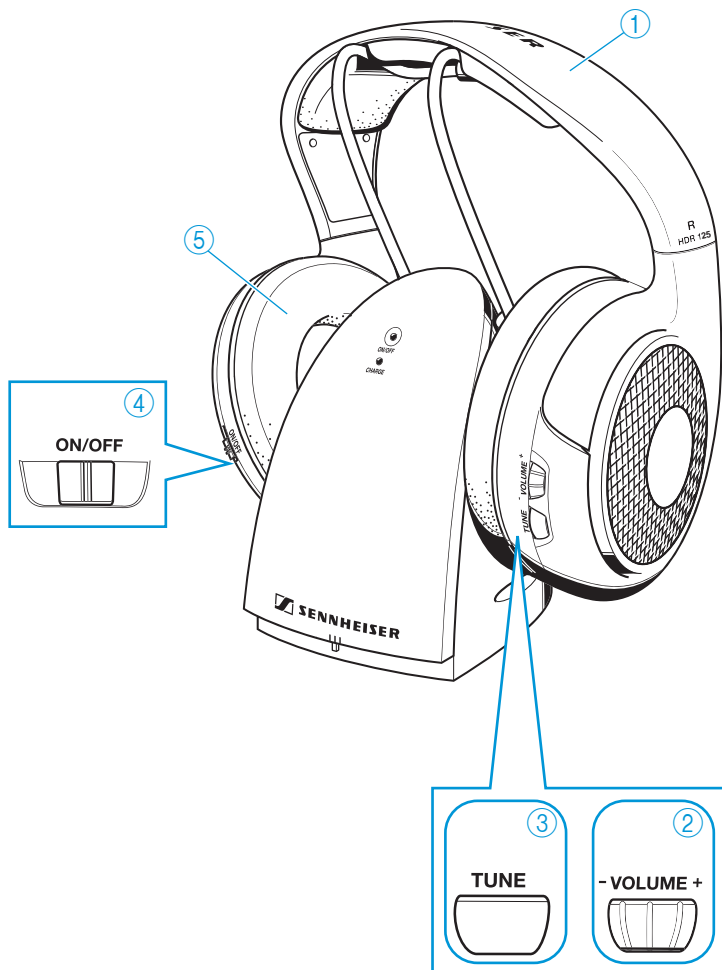

Instruction manual



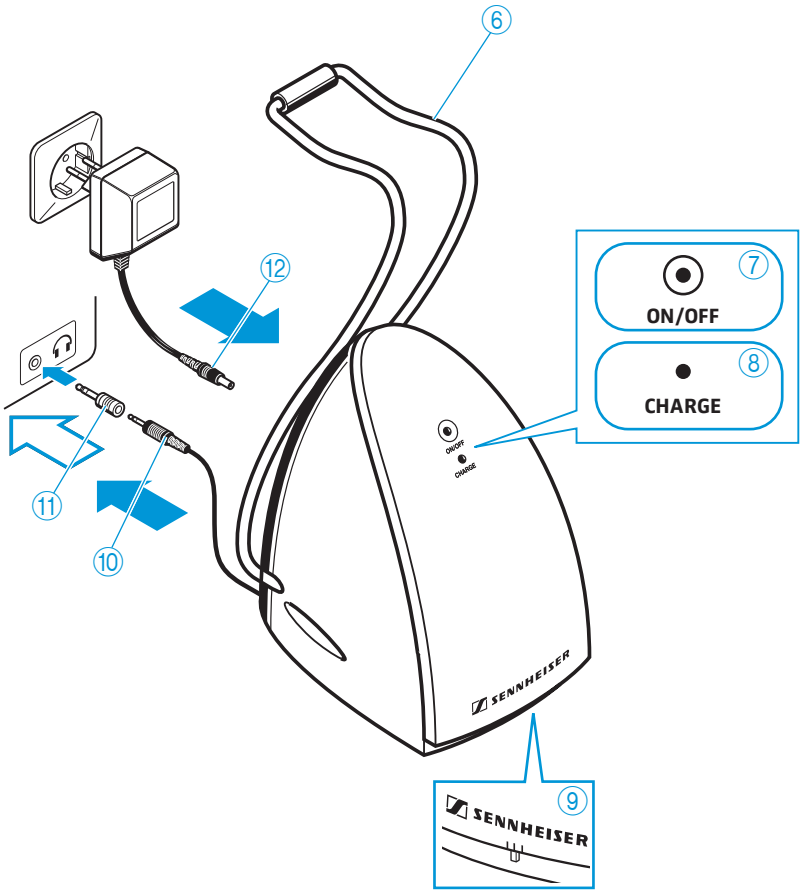

Contents

Important safety instructions	2
The RS 125 RF headphone system	4
Delivery includes	4
Product overview	5
Overview of the headphones	5
Overview of the transmitter	5
Overview of the indicators and acoustic signals	6
Putting the RS 125 system into operation	7
Setting up the transmitter	7
Connecting the transmitter to a sound source	8
Connecting the transmitter to the mains	9
Inserting and changing the headphones' rechargeable batteries	9
Charging the headphones' rechargeable batteries	10
Adjusting the headband of the headphones	11
Using the RS 125 system	12
Switching the transmitter on and off	12
Switching the headphones on and off	13
Searching for a sound source	14
Changing the transmission channel	15
Adjusting the volume	15
Switching the acoustic signals (beeps) on and off	16
Cleaning the RS 125 system	17
If a problem occurs	18
Accessories and spare parts	20
Specifications	20
Manufacturer declarations	22
Index	23

Important safety instructions

- Read this instruction manual.
- Keep this instruction manual for future reference. Always include this instruction manual when passing the devices on to third parties.
- Clean the devices and the mains unit only with a dry cloth.
- **WARNING:** To reduce the risk of fire or electric shock, do not expose the devices and the mains unit to rain or moisture.
- Only use the supplied mains unit.
- Disconnect the mains connector from the wall socket
 - to completely disconnect the devices from the mains,
 - during lightning storms or when unused for long periods of time.
- Ensure that the mains unit is
 - always readily operable and easily accessible,
 - properly plugged into the wall socket,
 - only operated within the permissible temperature range (see “Specifications” on page 20),
 - not covered or exposed to direct sunlight for longer periods of time in order to prevent heat accumulation.

Intended use of the devices

Intended use includes:

- having read this instruction manual, especially the chapter “Important safety instructions”,
- using the devices within the operating conditions and limitations described in this instruction manual.

“Improper use” means using the devices other than as described in this instructions, or under operating conditions which differ from those described herein.















Safety instructions for NiMH rechargeable batteries

If abused or misused, rechargeable batteries may leak. In extreme cases, they may even present:



- a heat hazard,
- a fire hazard,
- a leakage hazard,
- an explosion hazard,
- a smoke or gas hazard.

Please understand that Sennheiser does not accept liability for damage arising from abuse or misuse.

	Keep away from children.		Only use original Sennheiser rechargeable batteries.
	Observe correct polarity.		Do not short-circuit.
	Do not expose to moisture.		Switch rechargeable battery-powered devices off after use.
	Do not pack charged batteries loose – danger of shorting out / fire hazard.		When not using rechargeable batteries for extended periods of time, charge them regularly (about every three months).
	Do not continue to use defective rechargeable batteries.		Do not heat above 70°C/158°F, e.g. do not expose to sunlight or throw into a fire.
	Do not mutilate or dismantle.		Only charge rechargeable batteries at ambient temperatures between 10°C and 40°C.
	Immediately remove rechargeable batteries from obviously defective devices.		Dispose of rechargeable batteries at special collection points or return them to your specialist dealer.
	Only charge rechargeable batteries with the appropriate Sennheiser chargers.		

The RS 125 RF headphone system

The RS 125 RF stereo hi-fi headphone system offers excellent sound quality and allows for wireless listening everywhere in the house and garden. The lightweight headphones are extremely comfortable to wear and very easy to use.

The volume can easily be adjusted to individual needs. Enjoy a completely unrestricted listening experience without disturbing others.

Delivery includes

- 1 HDR 125 headphones
- 1 TR 125 transmitter with connection cable
- 2 AAA size NiMH rechargeable batteries, 1.2 V
- 1 NT-RS 100 mains unit
- 1 adapter 3.5 mm to ¼" (6.3 mm) jack socket
- 1 instruction manual

Product overview

An overview of the headphones and the transmitter is given on the inside front cover of this instruction manual.

I Overview of the headphones

- ① Headband
- ② Volume control (VOLUME)
- ③ Channel search button (TUNE)
- ④ ON/OFF switch
- ⑤ Earpad

II Overview of the transmitter



- ⑥ Charging cradle
- ⑦ Operation indicator, green
- ⑧ Charging indicator, red
- ⑨ Channel selector switch
- ⑩ Connection cable
- ⑪ Adapter for connection cable
- ⑫ Connector of mains unit

Overview of the indicators and acoustic signals

Indicators on the transmitter

Indicator	Status	Meaning
Operation indicator ⑦ (ON/OFF)	lit	The sound source and the transmitter are switched on.
Charging indicator ⑧ (CHARGE)	lit	The rechargeable batteries are being charged.
	flashes	The rechargeable batteries are fully charged.

Acoustic signals and their meaning

Acoustic signal		Meaning
	6 short beeps	No signal! The transmitter is switched off or out of range.
	2 long beeps	The rechargeable batteries are almost flat.
	Sequence of 3 beeps	The headphones have just been switched off.

Putting the RS 125 system into operation

Setting up the transmitter

- ▶ Choose a suitable place near your sound source (e.g. TV, stereo or home cinema system).
- ▶ Do not place the transmitter close to metal objects such as shelf supports, reinforced concrete walls, etc. as the metal affects the antenna and can decrease the transmitter's range. This can be up to about 150 m in good conditions.
- ▶ Choose a place for the transmitter where the antenna is in free space so that transmission can be as effective as possible.

It is not necessary that the transmitter and headphones are in the same room, so you can move around freely in the home or outside in the garden.



One transmitter can be used to transmit to several headphones on the same frequency.

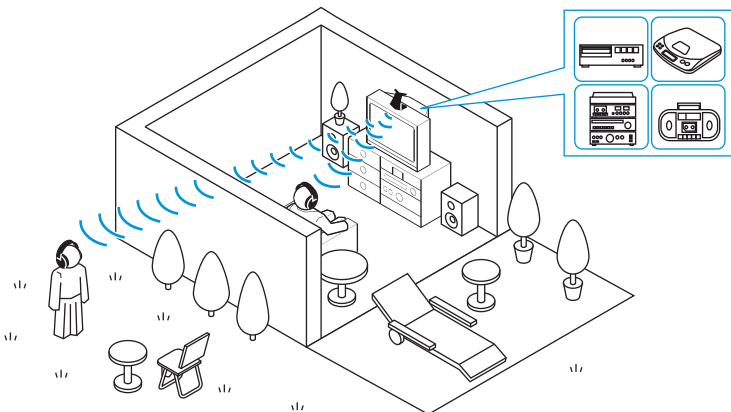

Wall mounting the transmitter

The transmitter is prepared for wall mounting. The required mounting hardware (screws and plugs) is not included in the delivery.

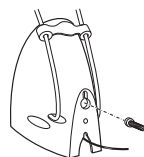

Connecting the transmitter to a sound source

You can connect the TR 125 transmitter to different sound sources, such as a TV, a DVD player or a stereo system.

- ▶ Switch your sound source off.

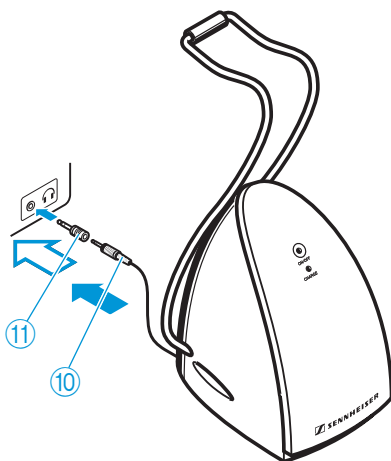

- ▶ Connect the connection cable ⑩ to the headphone socket of your sound source.
If the plug on the connection cable ⑩ is too small for your headphone socket, plug the adapter to 1/4" (6.3 mm) jack socket ⑪ onto the connection cable.

- ▶ Adjust the volume of the headphone socket on your sound source to a medium level. This improves the quality of cordless sound transmission. If necessary, check the menu setting of your TV.



With most TVs, the headphone socket is located at the front or sides.

Connecting the transmitter to the mains

- ▶ Connect the yellow connector of the mains unit ⑫ to the yellow socket on the transmitter.
- ▶ Plug the mains connector into a wall socket. The transmitter automatically switches on and the operation indicator ⑦ lights up.

If there is no signal from the sound source for more than three minutes, the transmitter automatically switches off and the operation indicator ⑦ goes off.

Disconnecting the transmitter from the mains

- ▶ Pull the mains connector out of the wall socket.

Inserting and changing the headphones' rechargeable batteries

Before using the RS 125 for the first time, you have to insert the supplied rechargeable batteries.

- ▶ Lift the left earpad ⑤ off as described in the chapter "Replacing the earpads" on page 17.

- ▶ Insert the rechargeable batteries. Observe correct polarity when inserting the batteries.
- ▶ Put the earpad ⑤ back in place.

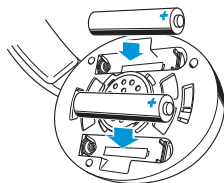

i If the operating time decreases drastically even when the rechargeable batteries are fully charged, the rechargeable batteries are exhausted and have to be replaced.

Charging the headphones' rechargeable batteries



Charge the rechargeable batteries for at least 16 hours prior to first time use. Subsequent charging time is about the same time as the previous operating time. The operating time is up to 23 hours.

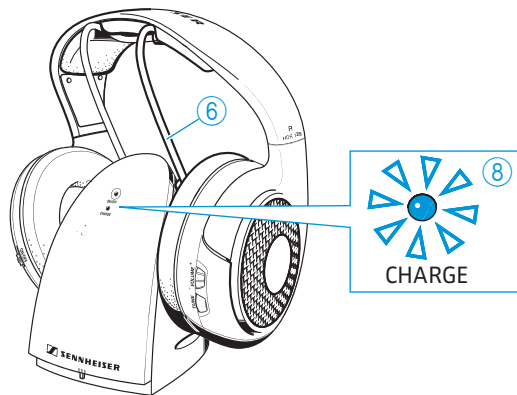

- ▶ Place the headphones on the charging cradle ⑥. Make sure that the charging indicator ⑧ lights up. The headphones automatically switch off and the rechargeable batteries are being charged.



Always store the headphones on the charging cradle ⑥ to ensure that they are fully charged when they are needed. When the rechargeable batteries are fully charged, the transmitter automatically switches to trickle charging and the charging indicator ⑧ flashes slowly.

Nearly discharged batteries will significantly reduce the sound quality. Approx. 10 minutes before the batteries are completely discharged, an acoustic signal is produced.

Adjusting the headband of the headphones

For good sound quality and best possible comfort, the headband has to be adjusted to properly fit your head:

- ▶ Wear the headphones so that the headband ① runs over the top of your head.
- ▶ Adjust the length of the headband so that
 - your ears are completely inside the earpads,
 - you feel even, gentle pressure around your ears,
 - a snug fit of the headband ① on the head is ensured.



Using the RS 125 system

To switch the devices on and to listen to your sound source, proceed as follows:

Sequence of steps	Page
1. Make sure that the rechargeable batteries are charged.	10
2. Switch your sound source (e.g. TV) on.	12
3. Switch your headphones on.	13
4. Set the desired volume.	15
5. If necessary, set a different channel for your sound source.	14

Switching the transmitter on and off

Switching the transmitter on

- ▶ Switch your sound source on.
The transmitter automatically switches on and the operation indicator ⑦ lights up.

If the transmitter does not switch on:

- ▶ Increase the volume of your sound source and, if necessary, read the chapter “The transmitter does not switch on” on page 18.

Switching the transmitter off

- ▶ Switch your sound source off.

If there is no signal from the sound source for more than three minutes, the transmitter automatically switches off and the

operation indicator ⑦ goes off. The transmitter is now in standby mode, its power consumption is very low so that it can remain connected to the mains.



When not using the devices for extended periods of time, pull out the mains connector from the wall socket. In this case, however, the headphones' rechargeable batteries will not be recharged.

Switching the headphones on and off

CAUTION! Hearing damage due to high volumes!



Listening at high volume levels for long periods can lead to permanent hearing defects.

- ▶ Before putting the headphones on, set the volume to a low level.
- ▶ Do **not** continuously expose yourself to high volumes.

Switching the headphones on

- ▶ Set the ON/OFF switch ④ on the headphones to the position **ON**.

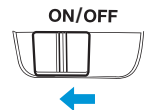

The headphones switch on and automatically start the channel search on the last selected channel. If a channel is found, the channel search stops. You hear the signal of the found sound source.

If you do not hear the sound source after a short while, please refer to the chapter "If a problem occurs ..." on page 18.

Switching the headphones off

- ▶ Set the ON/OFF switch ④ on the headphones to the position **OFF**.
The headphones switch off.

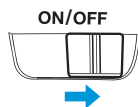

- ▶ Always store the headphones on the charging cradle ⑥ to ensure that they are fully charged when they are needed.

Searching for a sound source

- ▶ Make sure that the operation indicator ⑦ on the transmitter is lit.

If you do **not** hear the desired sound source, continue the search:

- ▶ Press the TUNE button ③ on the headphones until you have found your sound source.

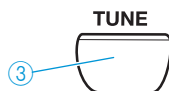

- ▶ If you cannot find your sound source, please read the following section.

Changing the transmission channel

If several transmitters are operated simultaneously and are very close to one another, the sound quality can deteriorate and you hear e.g. hissing noise. To improve the sound quality, change the transmission channel:

- ▶ Set the channel selector switch ⑨ on the transmitter to channel 1, 2 or 3.

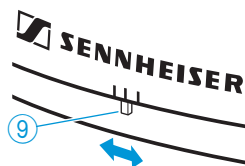

To set the headphones to the selected channel:

- ▶ Press the TUNE button ③ on the headphones.

Adjusting the volume

- ▶ Use the volume control ② to adjust the volume to a sufficient and comfortable level.

Switching the acoustic signals (beeps) on and off

An overview of the acoustic signals is given on page 6. The acoustic signals can be switched on and off as follows:

- ▶ Switch the headphones on (see page 13).
- ▶ Press the TUNE button  for 5 seconds.
- ▶ Switch the headphones off for testing (see page 13).
If the acoustic signals are switched on, the headphones produce a sequence of three beeps at switch-off. If no beeps are produced, the acoustic signals are now switched off.



The setting for the acoustic signals is retained in memory until you change the setting again or replace the rechargeable batteries.

Cleaning the RS 125 system

CAUTION! Liquids can damage the electronics of the devices!



Liquids entering the housing of the devices can cause a short-circuit and damage the electronics.

- ▶ Keep all liquids far away from the devices.
- ▶ Do not use any cleansing agents or solvents.

-
- ▶ Before cleaning, switch the devices off and disconnect the transmitter from the mains.
 - ▶ Only use a slightly damp cloth to clean the devices.

Replacing the earpads

For reasons of hygiene, you should replace the earpads from time to time. Spare earpads are available from your Sennheiser dealer (see “Accessories and spare parts” on page 20).

- ▶ To loosen the quarter turn fastener which secures the earpads to the earcups, turn the earpads ⑤ in the direction of the arrow until you overcome a slight resistance.
- ▶ Lift the earpads ⑤ off the earcups.

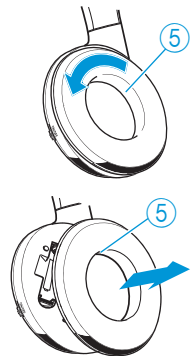

If a problem occurs ...

The transmitter does not switch on

Possible cause	Solution	Page
Is the mains unit connected correctly?	Check the connection of the mains unit to the transmitter and to the mains.	9
Is the volume of the sound source sufficient?	Set the volume on your sound source to a medium value.	12

You cannot hear anything

Possible cause	Solution	Page
Is the transmitter placed close to metal objects?	Choose a different place for the transmitter. Make sure that the transmitter is not placed close to metal objects.	7
Are the headphones still within the transmitter's range?	Move the headphones closer to the transmitter. If necessary, switch the headphones on again.	7
Are all connectors connected correctly?	Check the connection between the transmitter and your sound source.	8
Are the rechargeable batteries charged?	Place the headphones on the charging cradle. Check the charging indicator.	10
Are the rechargeable batteries properly inserted?	Remove the rechargeable batteries and reinsert them into the headphones.	9

The sound of your sound source is hardly intelligible

Possible cause	Solution	Page
You do not hear your desired channel?	Press the TUNE button ③ on the headphones to start the search for your desired channel.	14
Is there another transmitter operating in the proximity?	Set the transmitter to a different channel and press the TUNE button ③ on the headphones.	14

The loudspeakers of your TV are muted

Possible cause	Solution
Some TVs have a function that mutes the loudspeakers when you connect a transmitter.	Via the operating menu of your TV, check if and how the muting function can be deactivated.
	Alternatively, use a different audio socket on your TV.

If a problem occurs that is not listed in the above tables or if the problem cannot be solved with the proposed solutions, please contact your Sennheiser partner for assistance. For additional information on Sennheiser, please visit our website at www.sennheiser.com.

Accessories and spare parts

Only use original Sennheiser accessories and spare parts, otherwise the device quality can be impaired or the devices can be damaged.

Cat. No. Accessory/spare part

009932 1 HDR 125 additional headphones

511791 1 pair of earpads

Specifications

RS 125 system

Modulation	FM, stereo
Frequency range	863 – 865 MHz
Frequency response	18 – 21,000 Hz
Signal-to-noise ratio	typ. 68 dBA
Ambient temperature	0°C to +40°C

TR 125 transmitter

Carrier frequencies	863.3 / 864.0 / 864.7 MHz
Radiated RF power	≤ 10 mW
Power supply	9 V DC via NT-RS 100 mains unit
Power consumption	< 1.8 VA
Channels	3
Connector	3.5 mm stereo jack plug

TR 125 transmitter

Weight	approx. 430 g
Dimensions (incl. charging cradle)	approx. 85 x 133 x 225 mm (W x D x H)

HDR 125 headphones

Transducer principle	dynamic, circumaural, closed
Max. SPL (at 1 kHz)	104 dB
THD (at 1 kHz)	< 0.5%
Power supply	2 AAA size NiMH rechargeable batteries (LR 03)
Charging time	approx. 16 hrs (full charge)
Operating time	up to 23 hrs (with fully charged rechargeable batteries)
Weight	approx. 275 g incl. rechargeable batteries

NT-RS 100 mains unit

Nominal input voltage	230 V AC
Mains frequency	50 Hz
Nominal output voltage	9 V DC
Nominal output current	200 mA
Operating temperature range	0°C to +40°C

Transmitters that operate in the 863 – 865 MHz frequency range can be used licence-free in the following countries:
AT, BA, BE, CH, CY, CZ, DE, DK, EE, ES, FI, FR, GB, GR, HU, IE, IS, IT,
LI, LT, LU, LV, ME, MK, MT, NL, NO, PL, PT, RO, RS, SE, SI, SK, TR, UA.

Manufacturer declarations

Warranty

Sennheiser GmbH & Co. KG gives a warranty of 24 months on this product. For the current warranty conditions, please visit our web site at www.sennheiser.com or contact your Sennheiser partner.

CE Declaration of Conformity

CE 0682

This equipment is in compliance with the essential requirements and other relevant provisions of Directives 2006/95/EC and 1999/05/EC.

The declaration is available on the internet site at www.sennheiser.com. Before putting the equipment into operation, please observe the respective country-specific regulations!

Rechargeable batteries



The supplied rechargeable batteries can be recycled. Please dispose of them as special waste or return them to your specialist dealer. In order to protect the environment, only dispose of exhausted batteries.

WEEE Declaration



Your Sennheiser product was developed and manufactured with high-quality materials and components which can be recycled and/or reused. This symbol indicates that electrical and electronic equipment must be disposed of separately from normal waste at the end of its operational lifetime.

Please dispose of this product by bringing it to your local collection point or recycling centre for such equipment. This will help to protect the environment in which we all live.

Index

Headphones

- Adjusting the volume 15
- Automatic channel search 14
- Charging the headphones 10
- Cleaning 17
- Operating elements of the headphones 5
- Operating time 10
- Replacing the earpads 17
- Searching for a sound source 14
- Switching the acoustic signals on/off 16
- Switching the headphones on/off 13

Rechargeable batteries

- Changing the batteries 9
- Charging indicator 6
- Charging the batteries 10

Transmitter

- Changing the channel 15
- Cleaning 17
- Connection to a headphone socket 8
- Connection to a sound source 8
- Connection to the mains 9
- Installation 7
- Operating elements of the transmitter 5
- Switching the transmitter on/off 12
- Troubleshooting 18



Sennheiser electronic GmbH & Co. KG
Am Labor 1, 30900 Wedemark, Germany
www.sennheiser.com

Printed in China
Publ. 02/09
532024/A01